

## HPISE Motor Controller AC Semiconductor Motor Controller

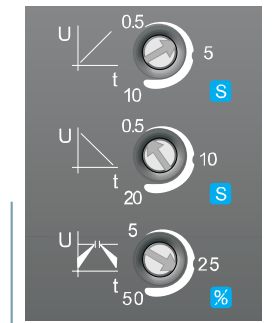

HPISE17...30



**SOLCOM&HAPN(SHANGHAI)ELECTRIC CO.,LTD**

Add:No.8017, Hutai Road,Shanghai P.C.201908

Tel:86-21-51805666 Fax:86-21-51805665

E-mail:solcom@solcom.com.cn <http://www.hapn.cn>

# HPISE2230-C10 HPISE4030-C10 HPISE4830-C10

## Types



- Soft starting and stopping of 3-phase squirrel cage motors
- Rated operational voltage: up to 480V AC RMS, 50/60Hz
- Rated operational current: up to 30AAC-53b
- Potential free control input
- LED-indications for power supply, ramping, bypassing relays
- Self protection against overheating
- Auxiliary relay output for end of ramp and overheating alarm
- Transient overvoltage protection built in
- Integral bypassing of semiconductors

## Product Description

Compact easy-to-use AC semiconductor motor controller. With this controller 3-phase motors with nominal load currents up to 30 A can be soft started and/or soft stopped. Starting time as well as initial torque and stopping can be independently adjusted by built-in potentiometers.

## Ordering Key

HP IS E 40 16 - C 10

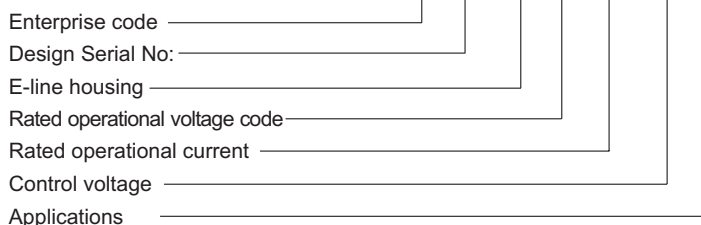

## Type Selection

Type	Rated operational voltage Ue	Rated operational current Ie	Control voltage Uc	Applications
HPISE:	22: 127/220 VAC rms, 50/60 Hz	25: 25 A	D: 24 V DC	10: For norma Applicationsl
E-series motor controller	40: 230/400 VAC rms, 50/60 Hz 48: 277/480 VAC rms, 50/60 Hz	30: 30 A	C: 100-240 V AC	S:Single phase R1:For fan and pump

## Selection Guide

Rated operational current Ie	Motor Rating		
	25A AC 53b	5.5 kW 7.5HP	11 kW 15HP
Rated operational current Ie	Motor Rating		
	30A AC 53b	7.5 kW 10HP	15 kW 20HP
	HPISE2225 - C10	HPISE4025 - C10	HPISE4825 - C10
	HPISE2230 - C10	HPISE4030 - C10	HPISE4830 - C10

## Input Specifications (Control Input)

Control voltage Uc A2-A3:	Passive contact terminal 100 - 240 VAC 24 VDC Approx. 5 mA
Rated insulation voltage	630 V rms Overvoltage cat. III (IEC 60664)
Dielectric strength	
Dielectric voltage	2kVAC (rms)
Rated impulse withstand volt.	4kV (1.2/50 μ s)

## Output Specifications

Utilization	Category	AC-53b Integral bypassing of semiconductors
Overload current profile (overload relay trip class)		25 A: AC-53b: 4-3: 120 30 A: AC-53b: 4-3: 150

## Supply Specifications

Power supply	Overvoltage cat. III (IEC60664)
Rated operational volt. (Ue) through terminals L1 - L2 -L3	(IEC 60038)
22	127/220 VAC rms $\pm 15\%$ 50/60 Hz -5/+5 Hz
40	230/400 VAC rms $\pm 15\%$ 50/60 Hz -5/+5 Hz
48	277/480 VAC rms $\pm 15\%$ 50/60 Hz -5/+5 Hz
Voltage interruption	$\leq 40$ ms
Dielectric voltage	2 kV (rms)
Rated impulse withstand volt.	4 kV (1.2/50 $\mu$ s)
Rated operational power supplied from	5 VA A2-A3

## Mode of Operation

This motor controller is intended to be used to soft start/stop 3-phase squirrel cage induction motors and thereby reduce the stress or wear on gear and belt/chain drives and to give smooth operation of machines. Soft starting and or stopping is achieved by controlling the motor voltage. During running operation the semiconductor is bypassed by an internal electromechanical relay. The initial torque can be adjusted from 5 to 50% of the nominal torque.

The soft-start time can be adjusted from 0.5 to 10 s and 0.5 to 20 s for the soft-stop respectively. A green LED indicates supply. The yellow LED is flashing during the ramping up or down. After the ramping when the semiconductors are bypassed the yellow LED lights constantly.

Alarm handling:

Over temperature: The HPISE will not start if the heatsink has an internal temperature which is exceeding approx 100%.

When over temperature occurs while the softstarter is not ramping (1) or while the bypass relays are activated

(2) the following will happen:

- 1) The softstarter will not ramp up and alarm relay is deactivated (contact open) - Reset takes place when the temperature drops below the critical level and only if the supply is interrupted and reapplied.
- 2) The alarm relay will deactivate (open) to indicate fault and when the softstarter is not ramping, the softstarter will react as described in 1).

## Functional Diagram

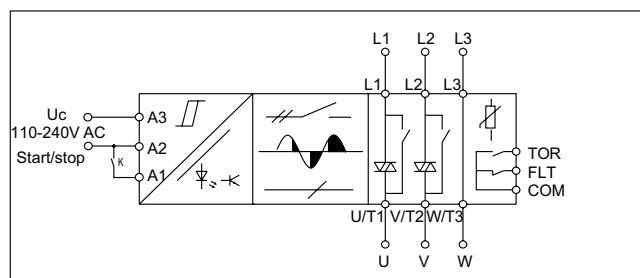

Specifications are subject to change without notice (2011.07.01)

## General Specifications

Accuracy	
Ramp up	$10 \pm 10\%$ on max. $\leq 0.5$ s on min.
Ramp down	$10 \pm 10\%$ on max.in. $\leq 0.5$ s on min.
Initial torque	$50\% \pm 5\%$ on max. < 5% on min.
EMC Immunity	Electromagnetic Compatibility acc.to EN 50 082-2
Indication for Power supply ON	LED, green
Ramping	LED, yellow (flashing)
Bypassing relay	LED, yellow (constant ON)
Environment Degree of protection	IP 20
Pollution degree	3
Operating temperature	$-20^{\circ}\text{C}$ to $+50^{\circ}\text{C}$ ( $-4^{\circ}\text{F}$ to $+122^{\circ}\text{F}$ )
Storage temperature	$-50^{\circ}\text{C}$ to $+85^{\circ}\text{C}$ ( $-58^{\circ}\text{F}$ to $+185^{\circ}\text{F}$ )
Terminals	Screw with captive wire clamp
Control terminals nominal Min.	2.5 mm <sup>2</sup> , AVG 14
Mounting torque max.	0.5 mm <sup>2</sup> , AWG 20 0.6 Nm
Power terminals nominal Min.	10 mm <sup>2</sup> , or 2 x 6 mm <sup>2</sup> AWG 6 or 2 x AWG 10
Mounting torque max.	1 mm <sup>2</sup> , AWG 16 2.0 Nm
CE-marking	Yes

## Dimensions

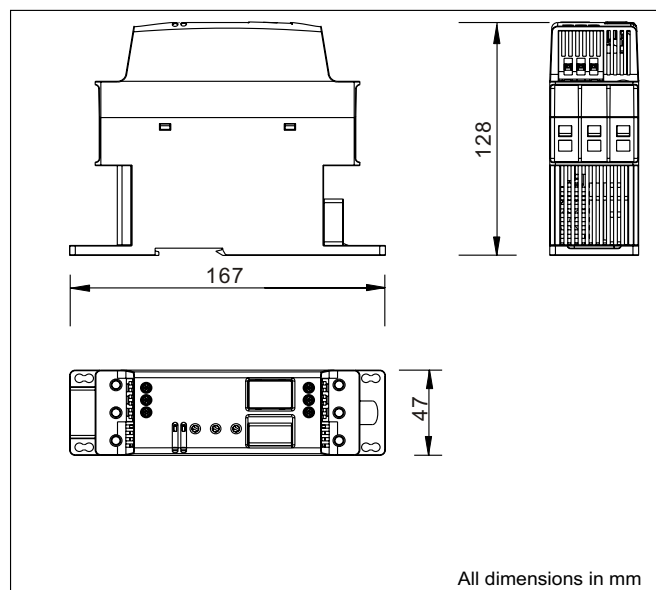

# HPISE2230-C10 HPISE4030-C10 HPISE4830-C10

## Operation Diagram 1

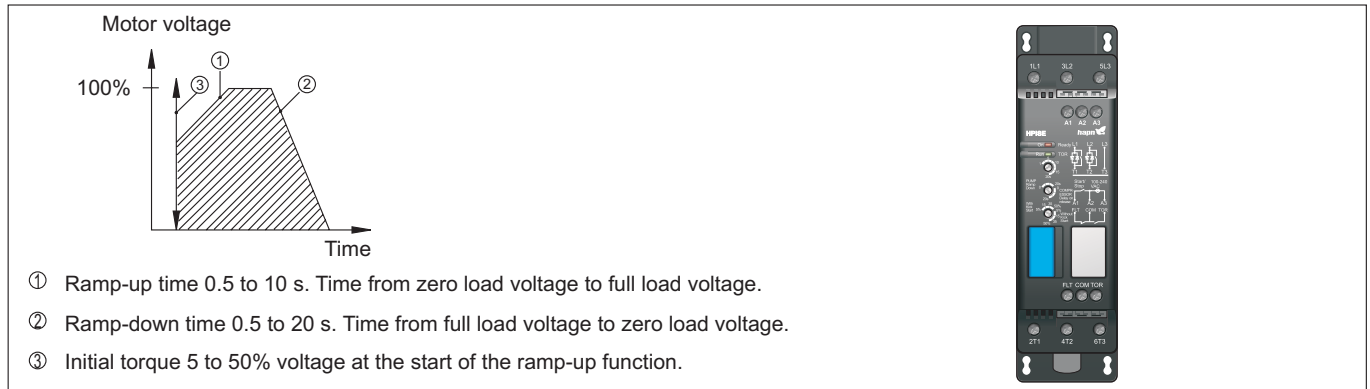

## Operation Diagrams 2 and 3

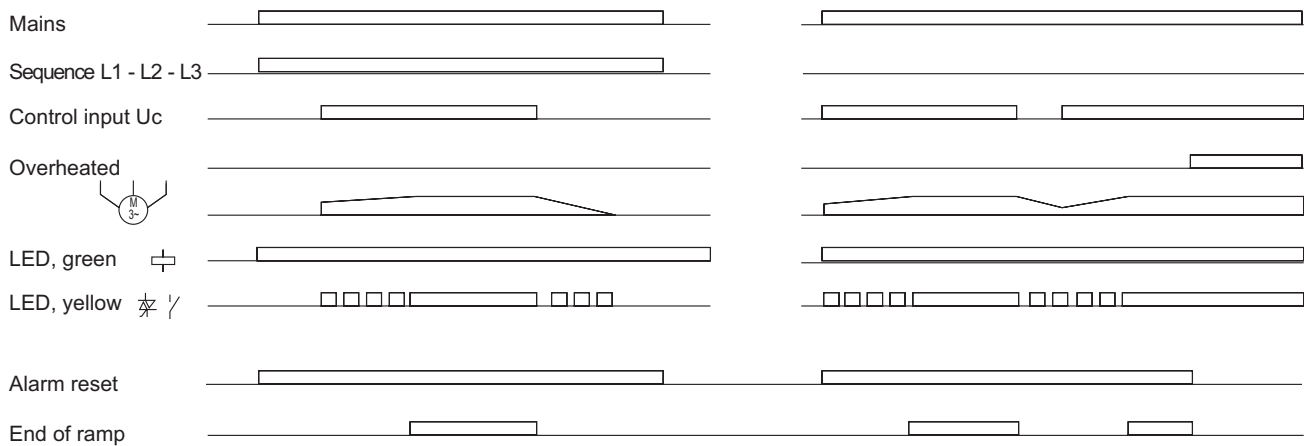

## Time between Rampings

Ramp time [sec.]	1	2	5	7	10
150	4 min	8 min	20 min	N/A	N/A
125	3 min	6 min	14 min	19 min	N/A
100	2 min	4 min	9 min	12 min	18 min
75	1 min	2 min	5 min	7 min	10 min
50	27sec	53sec	2 min	3 min	4 min
25	7sec	13sec	33sec	47sec	67sec

To prevent the semiconductors from overheating, a certain time between ramping should be allowed. The time between rampings depends on the motor current during ramping and ramp time(see table).

Note:

Table is valid for ambient temperature 25 °C . For higher ambient temperature add 5% °C to values in the table. The shaded areas in the table are for blocked rotor. Do not repeat rampings with blocked rotor.

## Housing Specifications

Housing material	PC/ABS Blend
Colour	Black
Terminal block	PBTP
Colour	Black
Bottom clips	POM
Colour	Light grey
Diode cover	PC
Colour	Grey Transparent
Front knob	PC
Colour	Black

Applications

Changing from direct-on-line start to soft start  
(Line controlled softstart)

(Fig.1)  
Changing a direct-on-line start into a soft start is very simple with the HPISE soft-starting relay:

- 1) Cut the cable to the motor and insert the HPISE relay.
- 2) Connect control input to two of the in coming lines. Set initial torque to minimum and ramp up and down to maximum.
- 3) Power up again - adjust the start torque so the motor starts turning immediately after power is applied, and adjust ramp time to the appropriate value.

When C1 is operated, the motor controller will perform soft-start of the motor. When C1 is switched off, the motor will stop, the motor controller will reset and after 0.5 s a new soft-start can be performed.

Please note that the controller does not insulate the motor from the mains. Contactor C1 is therefore needed as a service switch for the motor.

Recommended thermal-magnetic overload relay  
Selection Chart  
Thermal-magnetic overload relay and motor controller

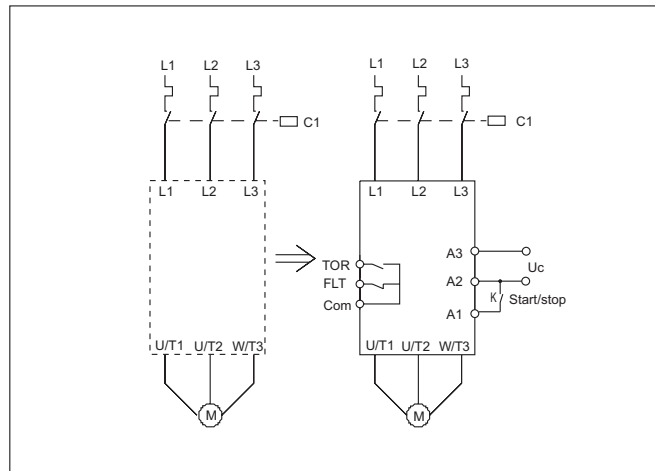

Fig. 1

Soft-start and soft-stop  
(Fig. 2)

When K is closed, soft-start of the motor will be performed according to the setting of the ramp-up potentiometer and the setting of the initial torque potentiometer. When K is opened, soft-stop will be performed according to the setting of the ramp-down potentiometer.

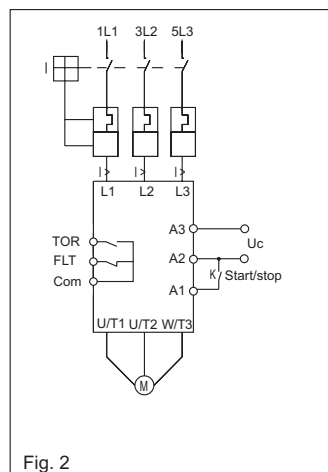

Fig. 2

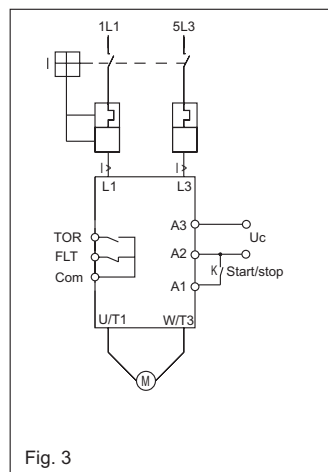

Fig. 3

Fusing Considerations

The motor controller provides bypassing of the semiconductor during running operation. Therefore the semiconductor can only be damaged by short-circuit currents during ramp-up and ramp-down function.

A 3-phase induction motor with correctly installed and adjusted overload protection does not short totally to earth as some other types of loads, eg: heater bands. In a failing motor, there will always be some part of a winding to limit the fault current. If the motor is installed in an environment where the supply to the motor cannot be damaged, the short circuit protection can be considered to be acceptable if the controller is protected by a 3-pole thermal-magnetic overload relay.

(Fig. 3)

The wiring diagram of the single-phase main circuit.